

Pressure Switch 600 Series



Switzer data sheet PS-DM600-01

Applications

- Hydraulics
- Pneumatics
- Fire Fighting
- Pumps Control
- Compressors Control
- Power
- Special Purpose Machine

Special Features

- Stainless Steel Diaphragm
- High Repeatability
- Weatherproof Enclosure
- Very Compact
- Tamper Proof Range Setting

Description

This compact version of Switzer 600 Series Pressure Switches using components of high reliability is specifically designed for OEMs such as Fire fighting, Boilers, Power Plants, SPMs.

The sensing Stainless Steel Diaphragm is welded to a Stainless Steel housing mounted external to the weatherproof instrument housing.

The mechanical movements are restricted to absolute minimum using a diaphragm which ensures long term stability.



DM 600

The instrument is in Pressure Die Cast Aluminium housing which is best suited for harsh and outdoor installations.

The sensing element and wetted part of 316 Stainless Steel is compatible for use in process applications with air, gas, water, steam, oil and other chemicals.

General Specifications

Enclosure

Aluminium pressure die cast weatherproof to IP:66

Repeatability (Note 1)

±1% FSR (Standard)

For special repeatability consult sales department

Range Setting

External with lock

Ranges

Refer Ordering Matrix (Note 2 & 3)

Differential

Fixed

1 × SPDT (Notes 4 & 5) : within 6 – 10% of FSR

2 × SPDT (Notes 4, 5 & 6) : within 10 – 15% of FSR

Adjustable (applicable for Range Codes **B32 & B33** only)

1 × SPDT (Notes 4 & 5) : between 15 & 30% of FSR

2 × SPDT (Notes 4, 5 & 6) : between 20 & 35% of FSR

Switching

Instrument quality snap acting microswitch.

Switch Rating

AC Rating — 15A, 250V

DC Rating — *Resistive* : 0.5A 110V / 0.25A 220V / 8A 24V

— *Inductive* : 0.2A 110V / 0.10A 220V / 7A 24V

Sensor / Wetted Parts

316L SS Diaphragm with 316 SS wetted parts

Max. Working Pressure

60 bar (all ranges)

Max. Fluid Temperature

170°C

Ambient Temperature

(–)10 to 60°C

Process Connection

1/4" NPT(F) or 1/2 " NPT(F) standard.

Adaptors for other threads optional

Electrical Connection

1/2" NPTF Nylon Cable gland for 8 mm OD cable (standard)

Mounting

On-line / Wall / Panel

Weight

600 Gms. approx.

Conformity

BS 6134 : 1991

Ordering Matrix

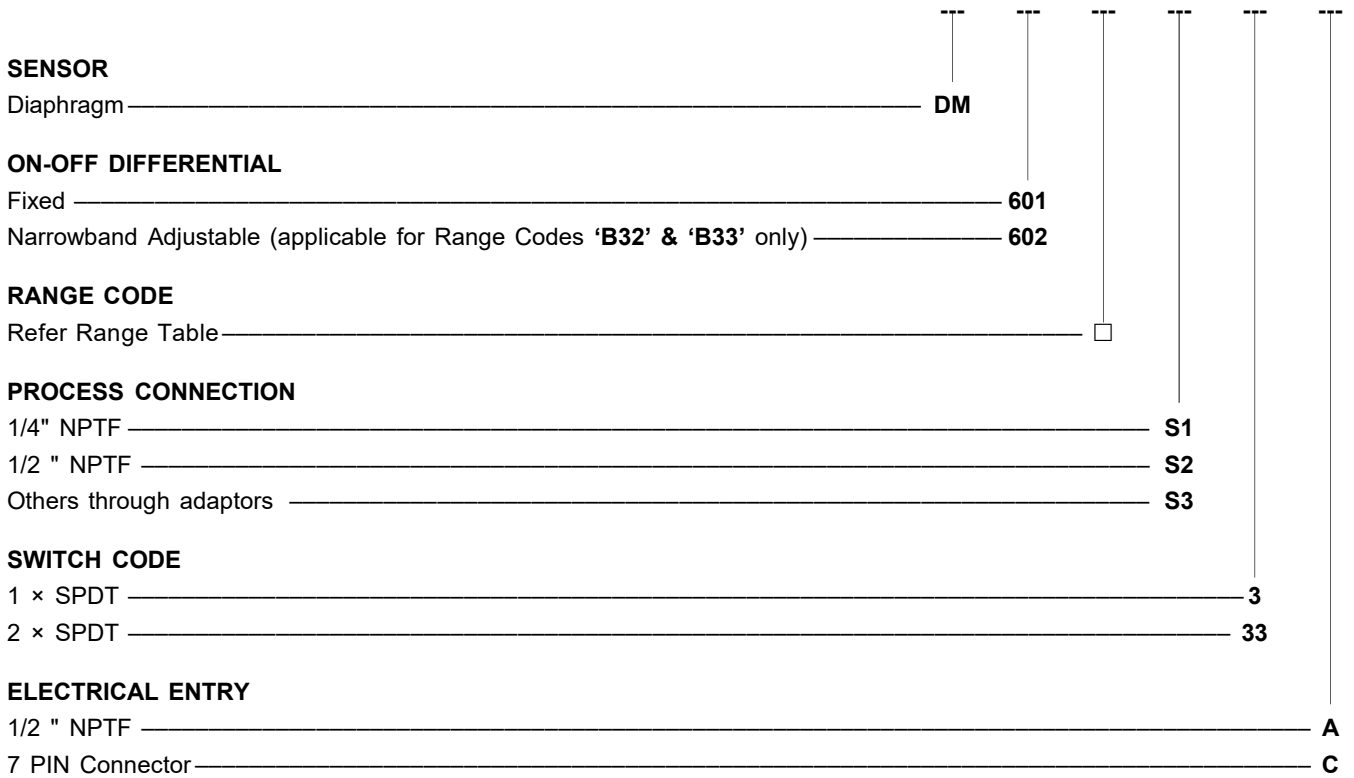

Range Table

RANGE CODE	RANGE (in bar)	Max. Working Pressure (in bar)
B26	0.2 to 1.6	60
B30	0.4 to 4	60
B32	0.7 to 7	60
B33	1 to 10	60
B35	1.6 to 16	60

Notes

1. Accuracy and repeatability are same for a Pressure Switch, which is a switching device and not a measuring instrument.
2. Select working range of the instrument such that the set pressure lies between 35% to 70% of range span.
3. On and off settings should not exceed the upper or lower range value.
4. Switching differentials are at midscale and will vary with range setting and operating conditions.
5. A pressure switch is a switching device and not a measuring instrument — eventhough it has a scale to assist setting. For this reason, Test Certificates will not contain individual ON-OFF switching values at different scale readings. Maximum differential obtained alone will be declared, besides other specifications.
6. DPDT action is achieved by 2 × SPDT switches synchronised to practical limits i.e., ± 2% of FSR.
7. Contact life of microswitches are 5×10^5 switching cycles for nominal load. To quench DC sparks, use diode in parallel with inductance, ensuring polarity. A 'R-C' network is also recommended with 'R' value in Ohms equal to coil resistance and 'C' value in micro Farads equal to holding current in Amps.
8. Higher process temperatures can be brought down by using longer pressure piping. Ask for piping nomogram # 441184-4.
Ensure that impulse pipework applies no stress on sensing element housing and use spanners to hold pressure port / housing when connections are made.
9. DM 600 is weatherproof only if all entries and joint faces are properly sealed.
10. A more versatile and wide range of Pressure & Differential Pressure Switches are available in Series 200, 020, 300, 931 & S20/920 Series upto 700 bar.
11. Accuracy figures are exclusive of test equipment tolerance on the claimed values.

Mounting Dimensions

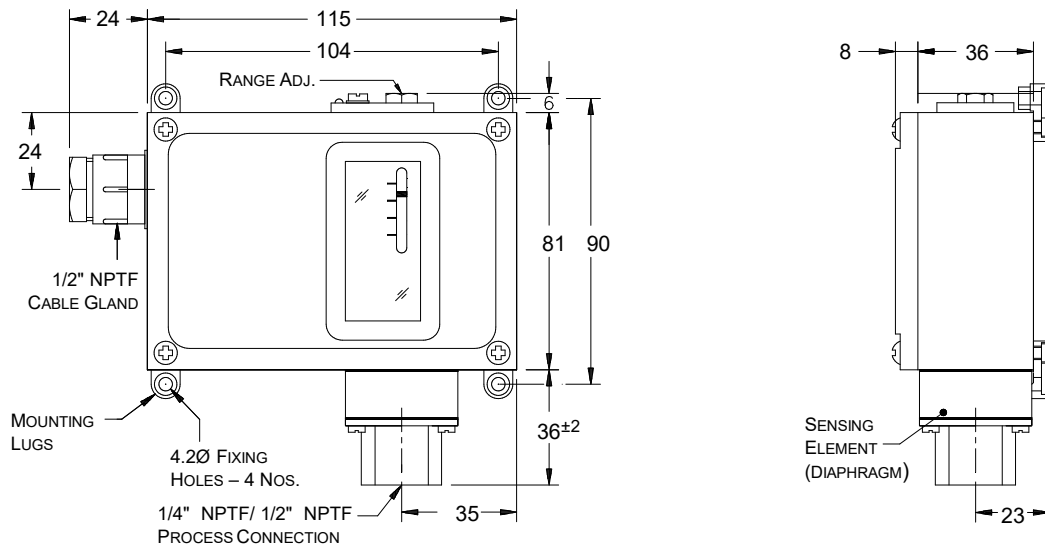

All dimensions are in mm

The specifications given in this document represent the state of engineering at the time of publishing. We reserve the right to make modifications to the specifications and materials.