



PRESSURE SWITCHES

**WEATHERPROOF
FLAMEPROOF**

S20 / 920 SERIES

- DIAPHRAGM-SEALED PISTON SENSOR ● HIGH STATIC PRESSURE ●
- FIELD ADJUSTABLE SETPOINT ● RUGGED DESIGN ●



**MODEL 924 IN GH
WEATHERPROOF ENCLOSURE**

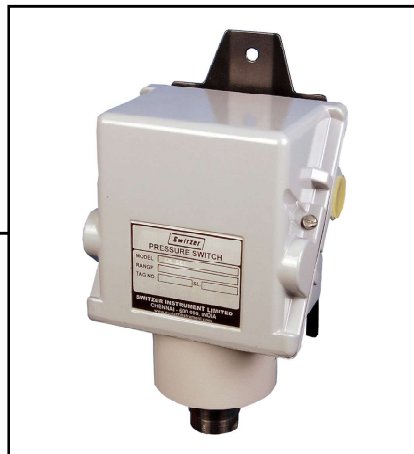

**MODEL S21 IN GM
WEATHERPROOF ENCLOSURE**



**MODEL S24 IN GK
FLAMEPROOF ENCLOSURE**

Rugged in construction, supreme in performance the S20 and 920 series pressure switches are designed as cost effective solutions to meet a variety of applications in the oil, gas, power, steel, Nuclear energy and petrochemical industries.

The sensing element consists of a time-proven diaphragm sealed piston affording high integrity, reliable switching and a very high overload protection. Variety of combinations in features are available to make it versatile.

GENERAL SPECIFICATIONS

| | | | |
|--------------------------|---|--|--|
| Enclosure | | Mounting | Direct or Wall or Pipe |
| GM | Aluminium pressure die cast weatherproof to IP:66 | Max. Working Pr. | Refer tables 'A' & 'B' |
| GA | Stainless steel investment cast weather-proof to IP:66 | Max. Working Temp. | - 20 to + 80°C for all ranges except - 20 to + 60°C for ranges U7, V7, W7 & Y4 (Note 14) |
| GK | Aluminium die cast, weatherproof to IP:66 and flameproof to Gr.IIA, IIB or IIC (Note 1) | Ambient Temp. Switching Element | - 10 to + 60°C (Refer Note 14) |
| GH | Aluminium pressure die cast weatherproof to IP:66 | Differential Connection Process | Instrument quality snap-acting SPDT microswitch Fixed; for values refer tables 'A' & 'B' |
| Ranges | (-1) to 700 bar -several std. ranges. Refer Table-1 | Electrical | |
| Sensor | 316L SS Diaphragm-sealed piston std. Monel optional | GM / GA | 3/4" ETF std; 1/2" NPTF optional. Dual entry on request. |
| Wetted Parts | | GK | 1/2" NPTF std. Dual entry on request. |
| Diaphragm Housing | 304 SS Standard 316 SS & Monel® – Optional | GH | 3/4" ET Nylon cable gland std. |
| Seal | Nitrile – Std ; EPDM /Teflon / Viton® – Optional | Conformity | Generally to BS : 6134 : 1991 |
| Repeatability | ± 1 % FSR (Note 4) | | |
| Scale Accuracy | ± 5 % FSR (for GH only) (Note 6) | | |

* Monel® is a registered trademark of The International Nickel Company, Inc * Viton® is a registered trademark of DuPont Dow Elastomers

ORDERING MATRIX

ENCLOSURE

Aluminium pressure die cast weatherproof to IP:66. **GM**

Stainless steel investment cast weatherproof to IP:66 for aggressive atmospheres ideal for offshore. **GA**

Aluminium die cast flameproof cum weatherproof. CIMFR approved to Gr.IIA IIB & IIC of IS/IEC 60079-1:2007 for flame-proofness and IP:66 for weatherproofness. **GK**

Aluminium pressure die cast compact housing. Weatherproof IP:66. **GH**

MODEL

S20 Series

(available in Style GA & GK enclosures only)

Fixed differential with maximum working pressures upto 155 bar as per table 'A'. **S21**

Fixed differential with maximum working pressures upto 1000 bar as per table 'B'. **S24**

920 Series

(available in Style GH enclosure only)

Fixed differential with maximum working pressures upto 155 bar as per table 'A'. **921**

Fixed differential with maximum working pressures upto 1000 bar as per table 'B'. **924**

MATERIALS OF WETTED PARTS

316L SS diaphragm, Nitrile 'O' ring and 304 SS wetted parts. **04**

316L SS diaphragm, Nitrile 'O' ring and 316 SS wetted parts. **02**

316L SS diaphragm, Nitrile 'O' ring and 316 SS wetted parts. **0L**

316L SS diaphragm, Viton 'O' ring and 316 SS wetted parts for NACE MR-01-75. **0N**

Monel diaphragm, Nitrile 'O' ring and 316 SS wetted parts. **M2**

Monel diaphragm, Viton 'O' ring and Monel wetted parts for NACE MR-01-75. **0M**

316L SS diaphragm and 316 SS wetted parts – Welded* construction. **W2**

RANGE CODE : Refer Table-1

SWITCH CODE AND RATING : Refer Table-2

ELECTRICAL ENTRY : Refer Table-3

Table – 1 : RANGE CODE & AVAILABILITY

| RANGE CODE | RANGE (in bar) | MODELS | | | |
|------------|-----------------|--------|-----|-----|-----|
| | | S21 | S24 | 921 | 924 |
| G3 | (-)1 to (+) 1.5 | ✓ | × | ✓ | × |
| DB | 0.25 to 1.6 | ✓ | × | ✓ | × |
| DC | 0.4 to 2.5 | ✓ | ✓ | ✓ | ✓ |
| DE | 1 to 6 | ✓ | ✓ | ✓ | ✓ |
| EA | 1.6 to 10 | ✓ | ✓ | ✓ | ✓ |
| EB | 2.5 to 16 | ✓ | ✓ | ✓ | ✓ |
| EC | 4 to 25 | ✓ | ✓ | ✓ | ✓ |
| ED | 10 to 40 | ✓ | ✓ | ✓ | ✓ |
| FA | 10 to 100 | ✓ | ✓ | ✓ | ✓ |
| U7 | 7 to 160 | × | ✓ | × | ✓ |
| V7 | 25 to 250 | × | ✓ | × | ✓ |
| W7 | 50 to 400 | × | ✓ | × | ✓ |
| Y4 | 100 to 700 | × | ✓ | × | ✓ |

Table – 2 : SWITCH CODE RATING & AVAILABILITY (Note 8)

| SWITCH CODE (SPDT) | AC RATING | DC RATING IN AMPS | | | | | | AVAILABILITY OF SPDT AND DPDT IN MODELS |
|--------------------|----------------|-------------------|------|------|-----------|------|------|---|
| | | RESISTIVE | | | INDUCTIVE | | | |
| | | 220V | 110V | 24V | 220V | 110V | 24V | |
| D | 15A 250 / 125V | 0.2 | 0.4 | 2.0 | 0.02 | 0.03 | 1.0 | S21, S24, 921 & 924 |
| H | 10A 250 / 125V | 0.2 | 0.4 | 2.0 | 0.02 | 0.03 | 1.0 | S21, S24, 921 & 924 |
| 3 | 15A 250 / 125V | N.R. | N.R. | N.R. | N.R. | N.R. | N.R. | S21, S24, 921 & 924 |
| 4 | 1A 125V | N.A. | 0.5 | 0.5 | N.A. | 0.25 | 0.25 | S21, S24, 921 & 924 |
| 5 | 5A 250 / 125V | 0.2 | 0.4 | 4.0 | 0.2 | 0.4 | 3.0 | S21, S24, 921 & 924 |
| 6 | 0.1A 125V | N.R. | N.R. | 0.1 | N.R. | N.R. | N.A. | S21, S24, 921 & 924 |
| 7 | N.R. | N.R. | N.R. | 1.0 | N.R. | N.R. | 0.5 | S21, S24, 921 & 924 |
| 8 | 5A 250 / 125V | N.A. | N.A. | 5.0 | N.A. | N.A. | 3.0 | S21, S24, 921 & 924 |
| J | 5A 250V / 125V | N.A. | N.A. | 5.0 | N.A. | N.A. | 3.0 | S21, S24, 921 & 924 |
| K | 1A 250V / 125V | N.A. | N.A. | 1.0 | N.A. | N.A. | 0.5 | S21, S24, 921 & 924 |
| S | 5A 250 / 125V | 0.25 | 0.5 | 3.0 | 0.1 | 0.2 | 2.0 | S21, S24, 921 & 924 |
| R | 0.1A 250V | N.R. | N.R. | N.A. | N.R. | N.R. | N.A. | S21, S24, 921 & 924 |

Codes D & H – General purpose– AC & DC rating.

Code 3 – General purpose – only AC rating.

Code 4 – With Gold alloy contact.

Code 5 – For General purpose with good DC rating.

Code 6 – With Gold alloy contact (Low Rating)

Code 7 – Environmentally sealed switch with Gold plated contact.

Code 8 – Environmentally sealed switch with Silver contact.

Code J – Hermetically sealed, inert gas filled with Silver contact.

Code K – Hermetically sealed, inert gas filled with Gold plated contact.

Code S – IP:67 sealed microswitch with silver Alloy contact.

Code R – IP:67 sealed microswitch with gold plated contact

For DPDT, change switch code to "DD", "33", etc., while ordering

N.A. – Not Available

N.R. – Not Recommended

* For reduced risk against leakage under extreme or exceptional conditions the diaphragm is welded to the pressure housings eliminating the 'O' ring.

Table 3 : ELECTRICAL ENTRY

| Size * | Single Entry | | | Dual Entry | | |
|--|--------------|-----|----|------------|-----|-----|
| | GM/GA | GK | GH | GM/GA | GK | GH |
| 3/4" ETF | A | --- | A | M | --- | M |
| 1/2" NPTF | B | B | B | N | N | N |
| 3/4" NPTF ** | C | --- | C | O | --- | O |
| M20 × 1.5 ** | D | D | D | P | P | P |
| M16 × 1.5 ** | E | --- | E | Q | --- | Q |
| Through Connector – Plug and Socket in MS | | | | | | |
| 3 pin plug | 2 | --- | 2 | --- | --- | --- |
| 7 pin plug | 3 | --- | 3 | --- | --- | --- |
| 9 pin plug | 4 | --- | 4 | --- | --- | --- |
| * Cable gland available on request. | | | | | | |
| ** Through adaptor except for GK housing. | | | | | | |

SWITCHING DIFFERENTIAL DATA

TABLE – A

| Range Code | Range (bar) | On-off Differentials in bar | | | | | MWP (bar) |
|------------|-------------|-----------------------------|------|------|-------|---------|-----------|
| | | S21 / 921 | | | | | |
| | | 3/D/6/H | 4 | 5 | J / K | 7/8/S/R | |
| G3 | -1 to 1.5 | 0.05 | 0.06 | 0.25 | 0.45 | 0.40 | 15 |
| DB | 0.25 to 1.6 | 0.05 | 0.06 | 0.07 | 0.15 | 0.20 | 27 |
| DC | 0.4 to 2.5 | 0.05 | 0.06 | 0.07 | 0.15 | 0.20 | |
| DE | 1 to 6.0 | 0.10 | 0.12 | 0.35 | 0.40 | 0.25 | 70 |
| EA | 1.6 to 10 | 0.20 | 0.25 | 0.50 | 0.50 | 0.90 | |
| EB | 2.5 to 16 | 0.25 | 0.30 | 0.60 | 0.60 | 1.00 | 110 |
| EC | 4 to 25 | 0.75 | 0.80 | 1.20 | 2.30 | 1.80 | |
| ED | 10 to 40 | 1.20 | 1.25 | 1.70 | 3.50 | 3.00 | |
| FA | 10 to 100 | 2.25 | 2.30 | 3.50 | 7.00 | 6.00 | 155 |

Since the force required to operate the microswitches is higher in DPDT arrangement, for DPDT switching apply a multiplication factor of 1.6 on the differential values with SPDT arrangement. The above stated differentials are at midscale. It would be twice at maximum range and half at minimum range.

TABLE – B

| Range Code | Range (bar) | On-off Differentials in bar | | | | | MWP (bar) |
|------------|-------------|-----------------------------|------|------|-------|---------|-----------|
| | | S24 / 924 | | | | | |
| | | 3/D/6/H | 4 | 5 | J / K | 7/8/S/R | |
| DC | 0.4 to 2.5 | 0.30 | 0.35 | 0.50 | 0.50 | 0.50 | 600 |
| DE | 1.0 to 6.0 | 0.45 | 0.50 | 0.70 | 0.75 | 0.70 | |
| EA | 1.6 to 10 | 0.60 | 0.65 | 1.00 | 1.20 | 0.70 | |
| EB | 2.5 to 16 | 0.60 | 0.65 | 1.20 | 1.20 | 0.70 | |
| EC | 4 to 25 | 1.00 | 1.10 | 2.00 | 2.30 | 0.90 | |
| ED | 10 to 40 | 1.80 | 1.85 | 2.60 | 3.50 | 2.20 | |
| FA | 10 to 100 | 3.50 | 3.60 | 5.70 | 5.00 | 4.50 | |
| U7 | 7 to 160 | 5.25 | 5.80 | 9.00 | 10.0 | 8.00 | 1000 |
| V7 | 25 to 250 | 9.00 | 9.50 | 10.0 | 22.0 | 25.0 | |
| W7 | 50 to 400 | 15.0 | 16.0 | 20.0 | 30.0 | 35.0 | |
| Y4 | 100 to 700 | 20.0 | 22.0 | 25.0 | 45.0 | 50.0 | |

NOTES

- Gr.IIA & IIB of IS/IEC 60079-1:2007 is equivalent to NEC CL.1, Gr.C & D. Gr.IIC of IS/IEC 60079-1:2007 is equivalent to NEC CL.1, DIV.1, Gr.A & B.
- Style GM / GA / GH is weatherproof only if all entries and joint faces are properly sealed. Style GK is weatherproof only if cover 'O' ring is retained in position and flameproof only if proper FLP cable gland is used. It is recommended to procure cable glands along with GK instruments to avoid neglect of it while installation.
- Intrinsic Safety (Exi) — Pressure Switches are classified as simple apparatus as they neither generate nor store energy. Hence pressure switches in weatherproof (GM / GA) enclosures also may be used in intrinsically safe systems without certification provided the power source is certified IS. Because of the low voltages and currents it is recommended to use gold contact and / or sealed contacts.
- Accuracy & Repeatability are not different for all blind pressure switches. A shift of ±2% may be observed in setpoint when pressure falls from full static pressure. Settings will also shift with varying temperature.
- The instrument is calibrated in the mounting position depicted in the drawing. Mounting in any other direction will cause a minor range shift, especially in low and compound ranges. Ranges above 1 bar will not experience this shift.
- A pressure switch is a switching device and not a measuring instrument — eventhough it has a scale to assist setting in GH only. For this reason, Test Certificates will not contain individual ON-OFF switching values at different scale readings. Maximum differential obtained alone will be declared, besides other specifications.
- Select working range of the instrument such that the set value lies in the mid 35% of the range i.e., between 35% and 70% of range span.
- For switching differential values please refer respective Differential Table. Switching differentials furnished are nominal values under test conditions at mid-scale and will vary with range settings and operating conditions.
- On and off settings should not exceed the upper or lower range value.
- DPDT action is achieved by two SPDT switches synchronised to practical limits i.e., ±2% of FSR.
- Contact life of microswitches are 5×10^5 switching cycles for nominal load. To quench DC sparks, use diode in parallel with inductance, ensuring polarity. A 'R-C' network is also recommended with 'R' value in Ohms equal to coil resistance and 'C' value in micro Farads equal to holding current in Amps.
- Switching differentials for Instruments with chemical seal** — Apply a Multiplication factor of 1.3 for SPCO and 1.5 for DPCO to values given in Range Table for GM / GA housings and apply a multiplication factor of 1.2 for SPCO and 1.5 for DPCO to values of Differential Table for GK housings.
- All models of S20 and 920 series pressure switches can withstand full vacuum.
- Ambient temperature range: All models are suitable for operating within a range of ambient temperature from (-) 10°C to (+) 60°C provided the process does not freeze within this range. Below 0°C, precautions should be taken in humid atmospheres to prevent frost formation inside the instrument from jamming the mechanism. Occasional excursions beyond this range are possible but accuracy might be impaired. The microswitch is the limiting factor which should never exceed the limits (-) 25°C to (+) 80°C.
- Fluid Temperature: A pressure switch when connected to the process is not subjected to through flow and therefore is not fully exposed to the fluid temperature. Use of adequate length of impulse piping will greatly reduce excessive heating of the sensing element. For e.g., connection of 7.5 cm of 12 mm dia impulse piping will reduce water temperature of 100°C to 65°C at an ambient temperature of 50°C. Ask factory for piping nomogram #441184-4 for different temperatures.
- Ensure that impulse pipework applies no stress on sensing element housing and use spanners to hold pressure port / housing when connections are made.
- Accuracy figures are exclusive of test equipment tolerance on the claimed values.**
- All performance data are guaranteed to ±5%.**

MOUNTING DIMENSIONS

'GH' Enclosure

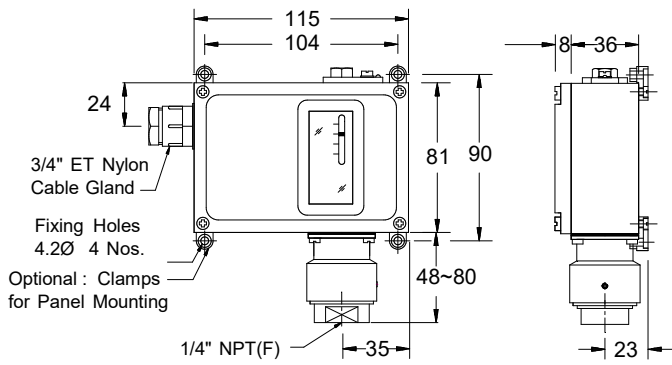

'GH' Enclosure with External Terminal Housing

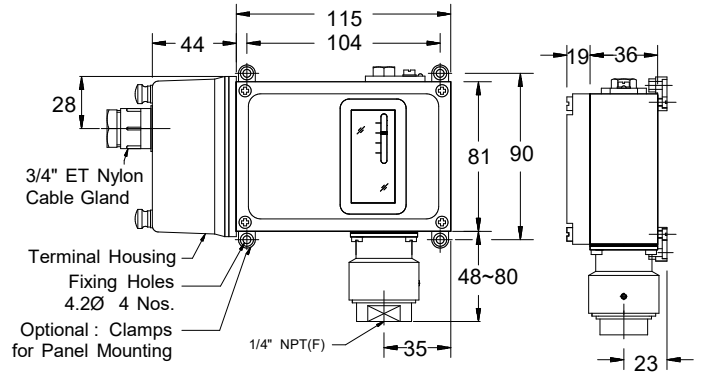

'GM' Enclosure

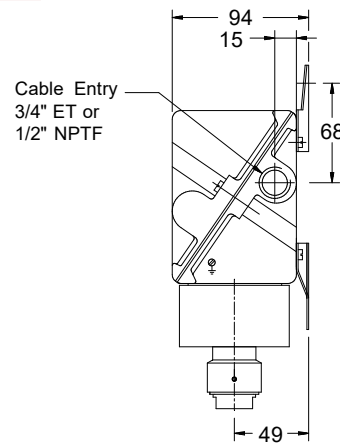
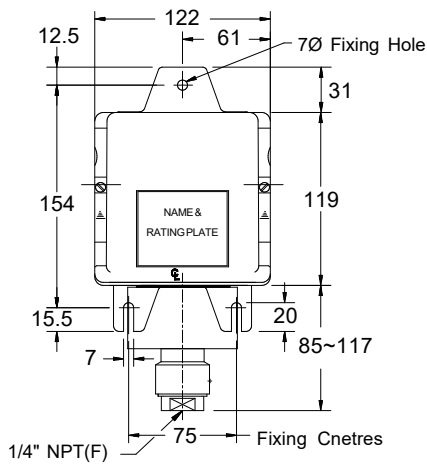

'GK' Enclosure

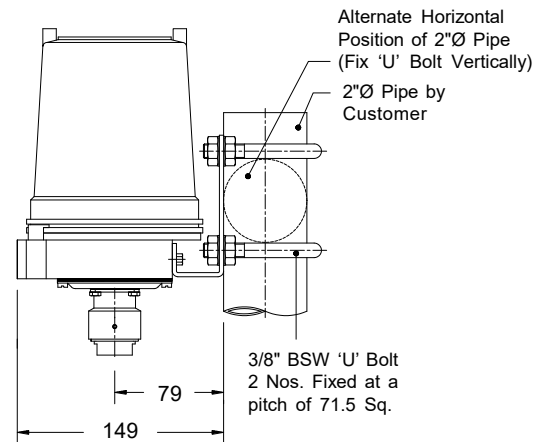
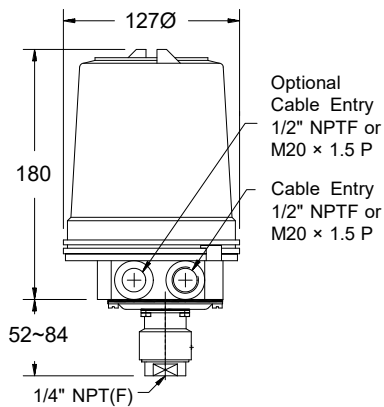

All dimensions are in mm

This is not a contractual document. Prior notification of changes in specifications is impracticable due to continuous improvement

Switzer **Switzer Process Instruments Pvt. Ltd.**