

## Pressure switch Model PS01

Switzer data sheet PS-PS01

### Applications

- Hydraulics and pneumatics
- Steel
- Power
- Special purpose machine

### Special features

- Diaphragm-sealed piston sensor and diaphragm
- High static pressure
- Field adjustable setpoint
- Robust design

### Description

These high quality pressure switches have been developed especially for safety-critical applications. High quality of the product with established systems and manufacturing process will ensure reliable monitoring of your plant.

Rugged in construction, supreme in performance PS01 pressure switches are designed as cost effective solutions to meet a variety of applications in oil, gas, power, steel and petrochemical industries.

The sensing element consists of a time-proven diaphragm sealed piston affording high integrity, reliable switching and a very high overload protection. Variety of combinations in features are available to make it versatile.

For low ranges, diaphragm is used as a measuring element.



**Fig. top: Pressure switch, model W1 weatherproof**  
**Fig. bottom: Pressure switch, model F1 flameproof**

## Standard version

### Switch enclosure

- W1: Aluminium pressure die cast weatherproof as per IS/IEC 60529
- F1: GR style aluminium pressure die cast, weatherproof and flameproof to Gr.IIA, IIB or IIC as per IS/IEC 60079

### Repeatability of the setpoint (note 4)

± 1.0% FSR

### Permissible ambient temperature

-10°C ... +60°C

### Permissible medium temperature

- -20°C ... +110°C for SS and Buna-N
- -20°C ... +95°C for Neoprene
- -20°C ... +130°C for EPDM
- -20°C ... +200°C for Silicone

### Process connection

- 1/4" NPT(F) direct
- Other connections through adaptor

### Measuring element

- 316L SS diaphragm sealed piston for high ranges (standard)
- Buna-N diaphragm for low ranges (standard)

### Wetted parts

- 316 SS standard (high ranges)
- Aluminium standard (low ranges)
- Monel® optional (high ranges)

### Sealing

- Nitrile standard
- EPDM / Teflon® / Viton® optional, depending on setting range and operating conditions

### Ranges

Several ranges from -1 ... +700 bar

### Switching contacts with microswitch

1 x SPDT or 2 x SPDT (single pole double throw)

### Switching function (notes 10)

Instrument quality snap acting microswitch

### On-off differential

- Fixed (standard)
- Wideband adjustable for low ranges in weatherproof enclosure only

### Maximum working pressure

Refer table 1

### Electrical connection

- 1/2" NPT(F) single entry standard
- Dual entry on request

### Ingress protection

IP66

### Scale accuracy (note 6)

± 5% FSR

### Mounting

Panel / wall / on-line / 2" pipe

### Conformity

Generally to BS 6134:1991

### Weight

- Weatherproof: approx. 1.3 Kg
- Flameproof: approx. 2.0 Kg

Teflon® is a registered trademark of E.I.Dupont de Nemours and Company

Viton® is a registered trademark of DuPont Dow Elastomers

Monel® is a registered trademark of The International Nickel Company, Inc

## Ordering matrix

Sample model number	PS01	W1	32	B02	F	5	A	P	C	SA
<b>Switch enclosure</b>										
Aluminium pressure die cast weatherproof to IP66		W1								
GR style aluminium pressure die cast, weatherproof to IP66 and flameproof to Gr.IIA, IIB or IIC.		F1								
<b>Material of sensing element and wetted parts</b>										
<b>Sensing element for high ranges</b>										
316L SS			3							
Monel			M							
<b>Sensing element for low ranges</b>										
Buna-N			B							
Neoprene			N							
EPDM			E							
Silicone			S							
316L SS			3							
<b>Wetted parts</b>										
316 SS			2							
Aluminium (applicable only for low ranges)			A							
Monel (applicable only for high ranges)			M							
<b>Range code:</b> Refer table 1 for available ranges										
<b>Differential</b> (Refer table 1 for available differential)										
Fixed										F
Adjustable (applicable only for weatherproof low ranges)										A
<b>Switch code and rating:</b> Refer table 2										
<b>Electrical entry:</b> Refer table 3										
<b>Mounting</b>										
Panel										P
Surface, wall										W
2" Pipe										2
<b>Mounting material</b>										
Mild steel										C
304 SS										4
316 SS										2
<b>Options:</b> Refer table 4										

### Remarks

- Weatherproof gasket: Nitrile gasket standard and EPDM on request for corrosive environment
- For special requirements, which is not listed in the above ordering matrix, will be indicated as Code 'Z' at the end of ordering code in quotation.

**Table 1: Range code and availability**

Range code	Range	Fixed (F)	Adjustable (A)	Maximum working pressure
<b>High ranges, measuring element diaphragm sealed piston</b>				
B02	-1 ... 1.5 bar	✓	×	15
B88	-1 ... 7 bar	✓	×	27
B42	0.25 ... 1.6 bar	✓	×	27
B43 *	0.4 ... 2.5 bar	✓	×	27
B44 *	1 ... 6 bar	✓	×	27
B45 *	1.6 ... 10 bar	✓	×	70
B46 *	2.5 ... 16 bar	✓	×	70
B37 *	4 ... 25 bar	✓	×	110
B39 *	10 ... 40 bar	✓	×	110
B47 *	10 ... 100 bar	✓	×	155
B48	7 ... 160 bar	✓	×	1000
B49	25 ... 250 bar	✓	×	1000
B50	50 ... 400 bar	✓	×	1000
B51	100 ... 700 bar	✓	×	1000
<b>Low ranges, measuring element diaphragm</b>				
M11	0 ... 2.5 mbar	✓	×	0.5
M36	0.5 ... 5 mbar	✓	✓	0.5
M37	1 ... 10 mbar	✓	✓	0.5
M38	2.5 ... 15 mbar	✓	✓	0.5
M39	2.5 ... 25 mbar	✓	✓	0.5
M41	5 ... 50 mbar	✓	✓	0.5
M45	7.5 ... 75 mbar	✓	✓	0.5
M46	10 ... 100 mbar	✓	✓	0.5
M57	20 ... 200 mbar	✓	✓	0.5
M47	40 ... 400 mbar	✓	✓	1
B25	0.2 ... 1 bar	✓	✓	4
B24	0.16 ... 1.6 bar	✓	✓	4
B30	0.4 ... 4 bar	✓	✓	7
M08	-5 ... 0 mbar	✓	✓	0.5
M06	-10 ... 0 mbar	✓	✓	0.5
M04	-20 ... 0 mbar	✓	✓	0.5
M03	-25 ... 0 mbar	✓	✓	0.5
M01	-50 ... 0 mbar	✓	✓	0.5
M49	-100 ... 0 mbar	✓	✓	0.5
M09	-2.5 ... +2.5 mbar	✓	×	0.5
M07	-10 ... +10 mbar	✓	✓	0.5
M05	-20 ... +20 mbar	✓	✓	0.5
M02	-50 ... +50 mbar	✓	✓	0.5

\* Optional MWP 600 bar is available

**Table 2: Switch code, rating and availability (note 10)**

Switch code		Contact version	AC rating	DC rating in Ampere					
SPDT	DPDT			Resistive			Inductive		
				220V	110V	24V	220V	110V	24V
D	DD	General purpose	15A 250, 125V	0.2	0.4	2.0	0.02	0.03	1.0
W ★	WW ★	General purpose	15A 250, 125V	0.3	0.6	10	0.05	0.1	4.0
5	55	General purpose	5A 250, 125V	0.2	0.4	4.0	0.2	0.4	3.0
9	99	Hermetically sealed, inert gas filled with Silver alloy contact	1A 115V, 400 Hz	N.A	N.A	3.0	N.A	N.A	1.0
G	GG	Hermetically sealed, inert gas filled with gold plated contact	N.A	N.A	N.A	1.0	N.A	N.A	0.25

- N.A – Not available
- ★ Applicable only for adjustable differential model

**Table 3: Electrical entry**

Size	Single entry		Dual entry	
	W1	F1	W1	F1
1/2" NPTF	A	A	N	N
Through connector				
7 pin plug	C	---	---	---
★ Cable gland available on request				

**Note:**

- All pin connectors housing material are of aluminium alloy
- In explosionproof pin connectors are not applicable.
- Cable gland available on request

**Table 4: Options**

Details	Code
Optional maximum working pressure	S5
Chemical seal ★	S1
Ammonia service	SA
Oxygen service	SO
NACE preparation	SC
Blow-out disc ★★	S8
Seal 'O' ring – Viton ★	OV
Seal 'O' ring – EPDM ★	OE
Seal 'O' ring – Teflon ★	OT
EPDM cover gasket for weatherproof enclosure W1	EW
★ Applicable for high ranges only	
★★ Not applicable for flameproof	

## Switching differential data for high ranges

Range code	Range in bar	On-off differential in bar						Maximum working pressure	
		Standard maximum working pressure			Optional maximum working pressure			Standard	Optional
		D	5	9 / G	D	5	9 / G		
B02	-1 ... 1.5	0.10	0.25	0.45	×	×	×	15	×
B88	-1 ... 7	0.30	0.35	4.0	×	×	×	27	×
B42	0.25 ... 1.6	0.15	0.15	0.15	×	×	×	27	×
B43	0.4 ... 2.5	0.15	0.15	0.15	0.30	0.50	0.50	27	600
B44	1 ... 6	0.20	0.35	0.40	0.45	0.70	0.75	27	600
B45	1.6 ... 10	0.25	0.50	0.80	0.60	1.00	1.20	70	600
B46	2.5 ... 16	0.30	0.60	1.00	0.60	1.20	2.00	70	600
B37	4 ... 25	1.00	1.20	2.30	1.00	2.00	4.00	110	600
B39	10 ... 40	1.30	1.70	3.50	1.80	2.60	5.00	110	600
B47	10 ... 100	2.25	3.50	5.00	3.50	5.70	8.00	155	600
B48	7 ... 160	5.25	9.00	10	×	×	×	1000	×
B49	25 ... 250	10	10	25	×	×	×	1000	×
B50	50 ... 400	18	20	35	×	×	×	1000	×
B51	100 ... 700	25	25	50	×	×	×	1000	×

- Above differential table is applicable for weatherproof and flameproof enclosures
- To arrive differential for DPDT arrangement apply multiplication factor 1.6
- Tabulated differential value is achievable at midscale
- Differential would be twice at upper limit of the range

## Switching differential data for low ranges with 316L SS diaphragm

Range code	Range	Weatherproof switch enclosure						Flameproof switch enclosure						
		on-off differential in mbar												
		Fixed						Adjustable			Fixed			
		D	5	9 / G			W	D	5	9 / G				
<b>Positive ranges</b>														
M11	0 ... 2.5 mbar	1.0	1.0	×	×	×	×	1.1	1.3	×	×	×	×	
M36	0.5 ... 5 mbar	1.2	1.2	×	×	×	×	1.4	1.8	×	×	×	×	
M37	1 ... 10 mbar	1.4	1.4	×	×	4 ... 6	×	1.4	1.8	×	×	×	×	
M38	2.5 ... 15 mbar	1.5	1.5	×	×	5 ... 9	×	1.6	2.3	×	×	×	×	
M39	2.5 ... 25 mbar	1.6	1.6	5	×	6 ... 15	×	2.3	2.5	7	×	×	×	
M41	5 ... 50 mbar	1.8	1.9	7	×	6 ... 30	×	2.3	3.3	8	×	×	×	
M45	7.5 ... 75 mbar	2.2	2.4	7	×	7 ... 45	×	2.6	3.6	8	×	×	×	
M46	10 ... 100 mbar	2.6	2.8	8	×	10 ... 60	×	3	4	8.5	×	×	×	
M57	20 ... 200 mbar	40	40	50	×	25 ... 80	×	40	50	50	×	×	×	
M47	40 ... 400 mbar	60	65	70	×	70 ... 240	×	50	70	75	×	×	×	
B25	0.2 ... 1 bar	80	85	125	×	115 ... 600	×	70	125	130	×	×	×	
B24	0.16 ... 1.6 bar	100	100	150	×	160 ... 960	×	90	150	175	×	×	×	
B30	0.4 ... 4 bar	130	135	200	×	300 ... 2400	×	135	200	220	×	×	×	
<b>Negative ranges</b>														
M08	-5 ... 0 mbar	1.2	1.3	×	×	×	×	1.2	2.2	×	×	×	×	
M06	-10 ... 0 mbar	1.4	1.8	×	×	4 ... 6.0	×	1.8	3.0	×	×	×	×	
M04	-20 ... 0 mbar	1.6	2.8	7	×	5 ... 12.0	×	2.2	4.6	7	×	×	×	
M03	-25 ... 0 mbar	2.0	3.0	8	×	6 ... 15.0	×	3.0	5.0	8	×	×	×	
M01	-50 ... 0 mbar	3.0	3.6	10	×	10 ... 30.0	×	4.0	6.0	10	×	×	×	
M49	-100 ... 0 mbar	3.4	4.2	12	×	15 ... 50.0	×	5.0	7.0	12	×	×	×	
<b>Compound ranges</b>														
		in +ve ranges	in -ve ranges	in +ve ranges	in -ve ranges	in +ve ranges	in -ve ranges		in +ve ranges	in -ve ranges	in +ve ranges	in -ve ranges	in +ve ranges	in -ve ranges
M09	-2.5 ... +2.5 mbar	1.0	1.4	1.0	1.3	×	×	×	1.1	1.6	1.2	2.0	×	×
M07	-10 ... +10 mbar	1.2	1.5	1.3	2.0	×	×	7 ... 10	1.3	2.2	1.6	3.0	×	×
M05	-20 ... +20 mbar	1.4	2.0	1.5	3.0	5	8	7 ... 20	1.6	3.0	2.8	4.0	6	8
M02	-50 ... +50 mbar	2.0	3.0	2.2	4.0	6	10	9 ... 50	2.2	4.0	3.0	6.0	7	10

■ To arrive differential for DPDT arrangement apply multiplication factor 1.8

## Switching differential data for low ranges with elastomer diaphragm

Range code	Range	Weatherproof switch enclosure				Flameproof switch enclosure								
		on-off differential in mbar												
		Fixed				Adjustable	Fixed							
		D	5	9 / G	W	D	5	9 / G						
<b>Positive ranges</b>														
M11	0 ... 2.5 mbar	1.0	1.0	×	×	1.0	1.1	×						
M36	0.5 ... 5 mbar	1.4	1.2	×	×	1.5	1.6	×						
M37	1 ... 10 mbar	1.5	1.2	×	3 ... 6	1.6	1.6	×						
M38	2.5 ... 15 mbar	1.5	1.2	×	4 ... 9	1.6	2.1	×						
M39	2.5 ... 25 mbar	1.5	1.5	5	6 ... 15	1.6	2.3	6.5						
M41	5 ... 50 mbar	1.5	1.6	6	7 ... 30	2.0	2.9	7.0						
M45	7.5 ... 75 mbar	1.6	1.8	6	10 ... 45	2.3	3.2	7.0						
M46	10 ... 100 mbar	1.5	2.0	8	12 ... 60	2.7	3.6	10						
M57	20 ... 200 mbar	15	20	40	25 ... 80	27	35	50						
M47	40 ... 400 mbar	20.0	30	60	60 ... 240	36	40	70						
B25	0.2 ... 1 bar	50	60	100	100 ... 600	60	90.0	120						
B24	0.16 ... 1.6 bar	70	60	150	150 ... 960	80	90.0	170						
B30	0.4 ... 4 bar	120	140	200	200 ... 2400	130	135.0	220						
<b>Negative ranges</b>														
M08	-5 ... 0 mbar	1.2	1.1	×	×	3	2.0	×						
M06	-10 ... 0 mbar	1.4	1.5	×	3 ... 6	8	2.7	×						
M04	-20 ... 0 mbar	1.5	2.3	7	4 ... 12	2.2	4.1	8						
M03	-25 ... 0 mbar	1.6	2.5	8	5 ... 15	3.0	4.5	10						
M01	-50 ... 0 mbar	2.0	3.0	10	5.5 ... 30	4.0	5.4	12						
M49	-100 ... 0 mbar	2.5	3.5	11	10 ... 50	5.0	6.3	13						
<b>Compound ranges</b>														
		in +ve ranges	in -ve ranges	in +ve ranges	in -ve ranges	in +ve ranges	in -ve ranges		in +ve ranges	in -ve ranges	in +ve ranges	in -ve ranges	in +ve ranges	in -ve ranges
M09	-2.5 ... +2.5 mbar	1.0	1.3	0.9	1.3	×	×	x	1.1	1.4	1.1	1.8	×	×
M07	-10 ... +10 mbar	1.1	1.5	1.2	1.6	×	×	3.2 ... 10	1.2	2.0	1.4	2.7	×	×
M05	-20 ... +20 mbar	1.3	1.5	1.3	2.0	4	6	5.0 ... 20	1.4	2.7	1.8	3.6	6	8.0
M02	-50 ... +50 mbar	1.5	2.0	1.5	3.0	6	8	10 ... 50	2.0	3.6	2.7	5.4	8	12

■ To arrive differential for DPDT arrangement apply multiplication factor 1.3

## Notes

1. Gr.IIA and IIB of IS/IEC 60079-1 is equivalent to NEC CL.1, Div.1, Gr.C and D. Gr.IIC of IS/IEC 60079-1 is equivalent to NEC CL.1, DIV.1, Gr.A and B.
2. Style W1 is weatherproof only when all entries and joint faces are properly sealed. Style F1 is flameproof only when cover 'O' ring is retained in position and proper FLP cable gland is used. It is recommended to procure cable glands along with F1 instruments to avoid neglect of it while installation.
3. Intrinsic Safety (Exi) — Pressure switches are classified as simple apparatus as they neither generate nor store energy. Hence pressure switches in weatherproof enclosures also may be used in intrinsically safe systems without certification provided the power source is certified Intrinsically Safe. Because of the low voltages and currents it is recommended to use gold contact and / or sealed contacts.
4. Accuracy and Repeatability are not different for all blind pressure switches. A shift of  $\pm 2\%$  may be observed in setpoint when pressure falls from full static pressure. Settings will also shift with varying temperature.
5. The instrument is calibrated in the mounting position depicted in the drawing. Mounting in any other direction will cause a minor range shift, especially in low and compound ranges. Ranges above 1 bar will not experience this shift.
6. A pressure switch is a switching device and not a measuring instrument even though it has a scale in W1 enclosure to assist setting. For this reason, Test Certificates will not contain individual ON-OFF switching values at different scale readings. Maximum differential obtained alone will be declared, besides other specifications.
7. Select working range of the instrument such that the set value lies in the mid 35% of the range i.e., between 35% and 70% of range span.
8. For switching differential values please refer Differential table. Switching differentials furnished are nominal values under test conditions at mid-scale and will vary with range settings and operating conditions.
9. On and off settings should not exceed the upper or lower range value.
10. DPDT action is achieved by two SPDT switches synchronised to practical limits i.e.,  $\pm 2\%$  of FSR. Deadband for DPDT contacts are higher than that of SPDT as force required to actuate the contacts are more. Please refer respective range table for exact values.
11. Fluid Temperature: A pressure switch when connected to the process is not subjected to through flow and therefore is not fully exposed to the fluid temperature. Use of adequate length of impulse piping will greatly reduce excessive heating of the sensing element. For e.g., connection of 75 mm of 12 mm dia impulse piping will reduce water temperature of 100°C to 65°C at an ambient temperature of 50°C. Consult sales for piping nomogram for different temperatures.
12. Ambient temperature range: PS01 suitable for operating within a range of ambient temperature from  $-10^{\circ}\text{C}$  ...  $+60^{\circ}\text{C}$  provided the process does not freeze within this range. Below  $0^{\circ}\text{C}$ , precautions should be taken in humid atmospheres to prevent frost formation inside the instrument from jamming the mechanism. Occasional escalation beyond this range are possible but accuracy might be impaired. The microswitch is the limiting factor which should never exceed the limits  $-25^{\circ}\text{C}$  ...  $+80^{\circ}\text{C}$ .
13. Ensure that impulse pipework applies no stress on sensing element housing and use spanners to hold pressure port/housing when connections are made.

# Dimensions in mm

Version PS01-W1

## High range direct or panel mouning

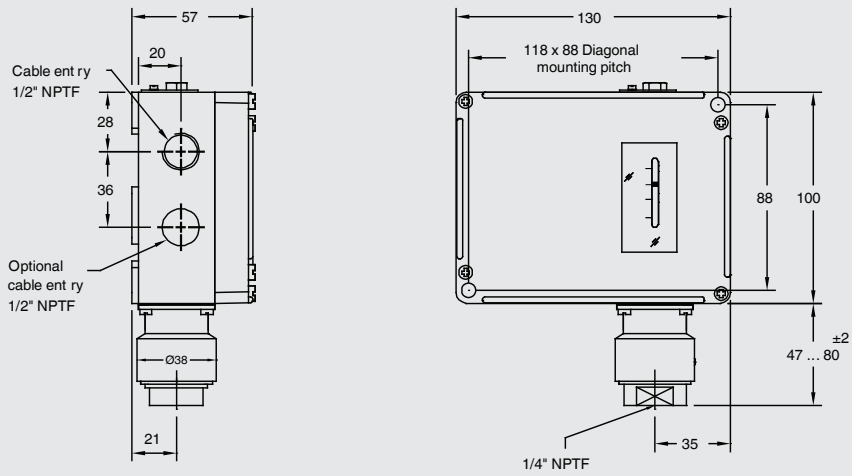

## High range 2" pipe mouning

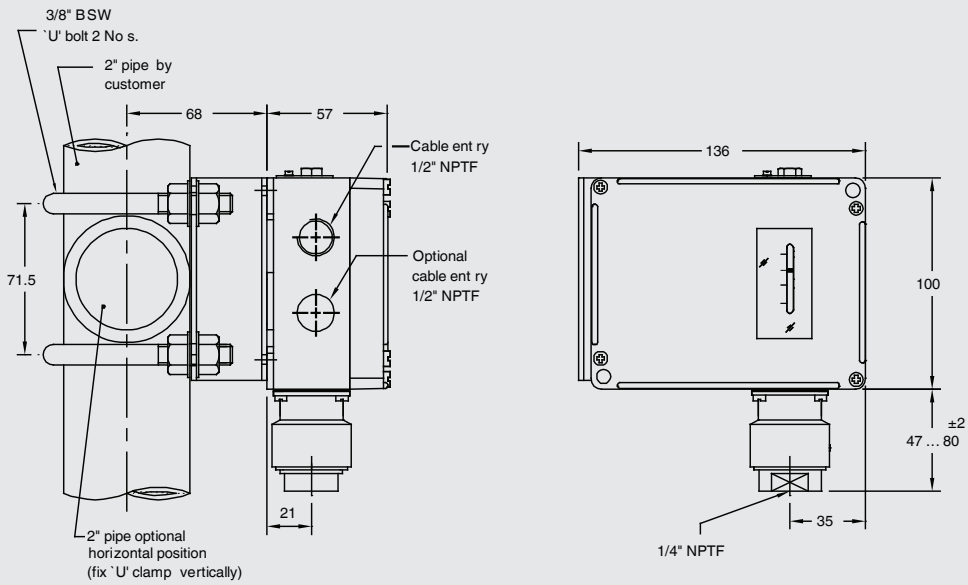

## Low range surface mouning

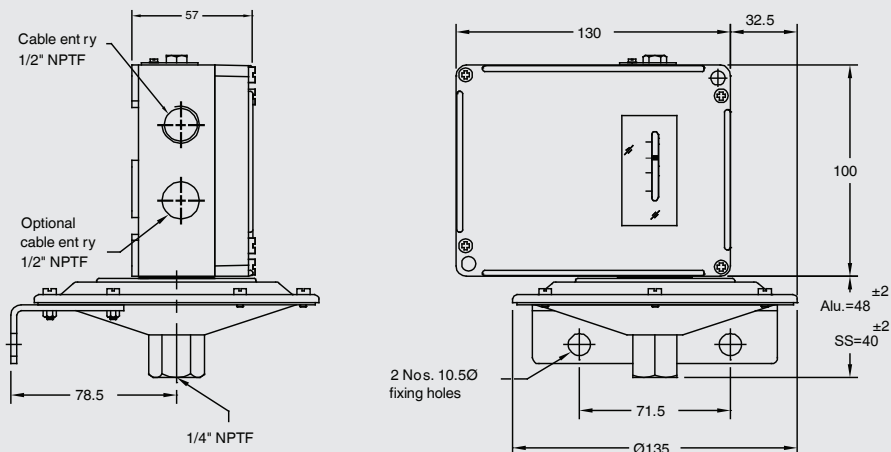

# Dimensions in mm

## Version PS01-F1

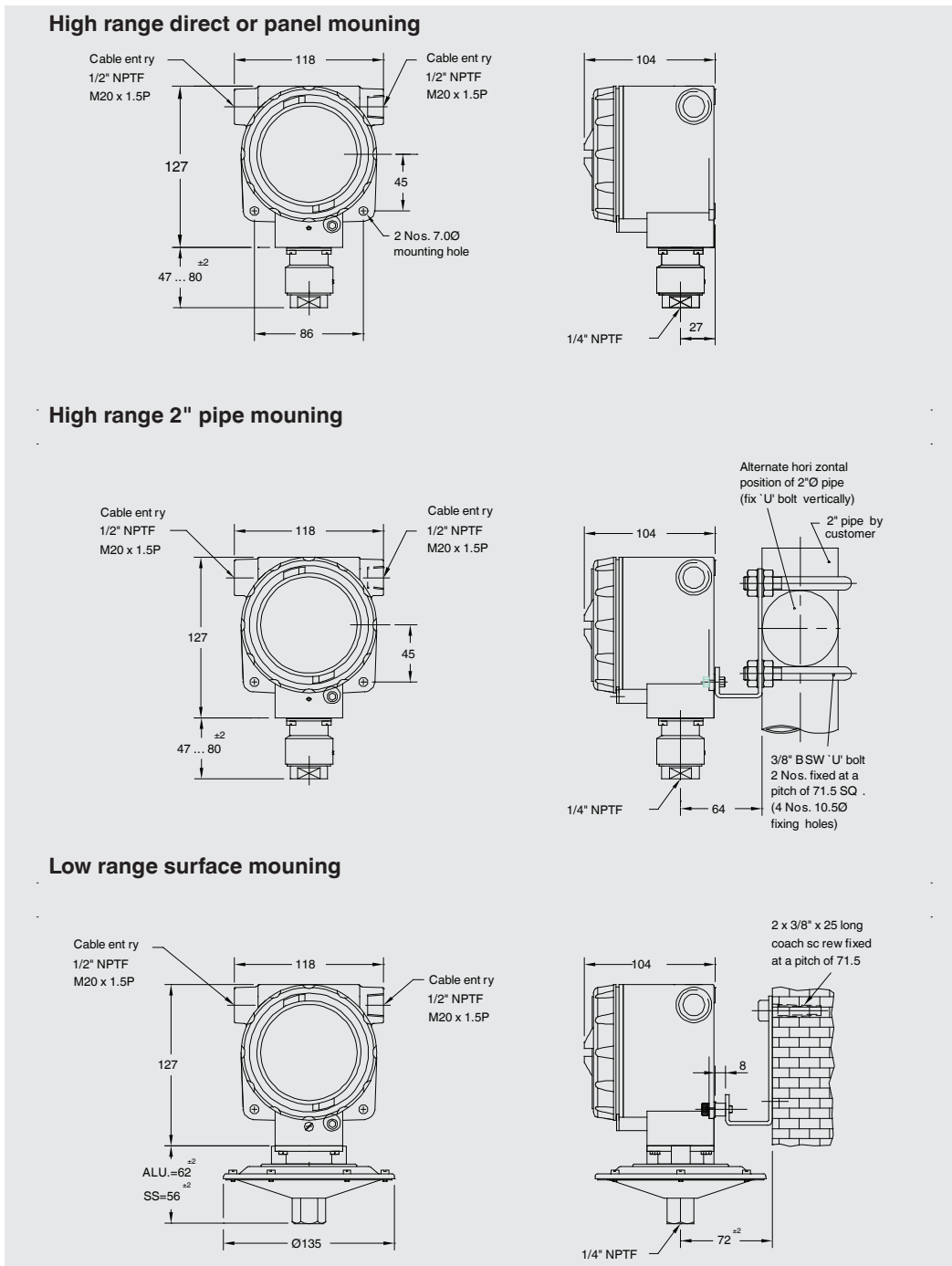

### Ordering information

Model / Sensing element, Wetted parts / Range code / Differential / Switch code and rating / Electrical entry / Mounting / Mounting material / Options

© 09/2016 Switzer Process Instruments Pvt. Ltd., all rights reserved.  
The specifications given in this document represent the state of engineering at the time of publishing.  
We reserve the right to make modifications to the specifications and materials.